

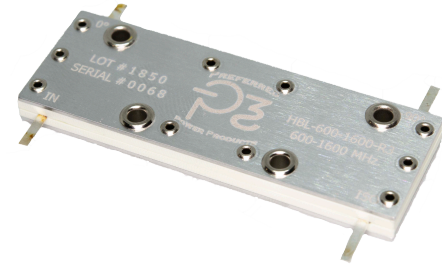

Data sheet HBL-600-1600-R3 REV A

600 - 1600 MHz. Model: HBL-600-1600-R3



HBL HYBR-LINE Series Drop-In Hybrid couplers provide High Power dividing or combining while exhibiting excellent phase and amplitude balance over continuous broadband operation. Solid compact designs are able to operate in a wide variety of environments, which include Medical, Industrial, Commercial wireless, Military, and Space. The **PP3** library of designs allows for modifications of standard designs to be made quickly and inexpensively to meet specific requirements with short delivery times. Consult factory for special requirements or frequency ranges.

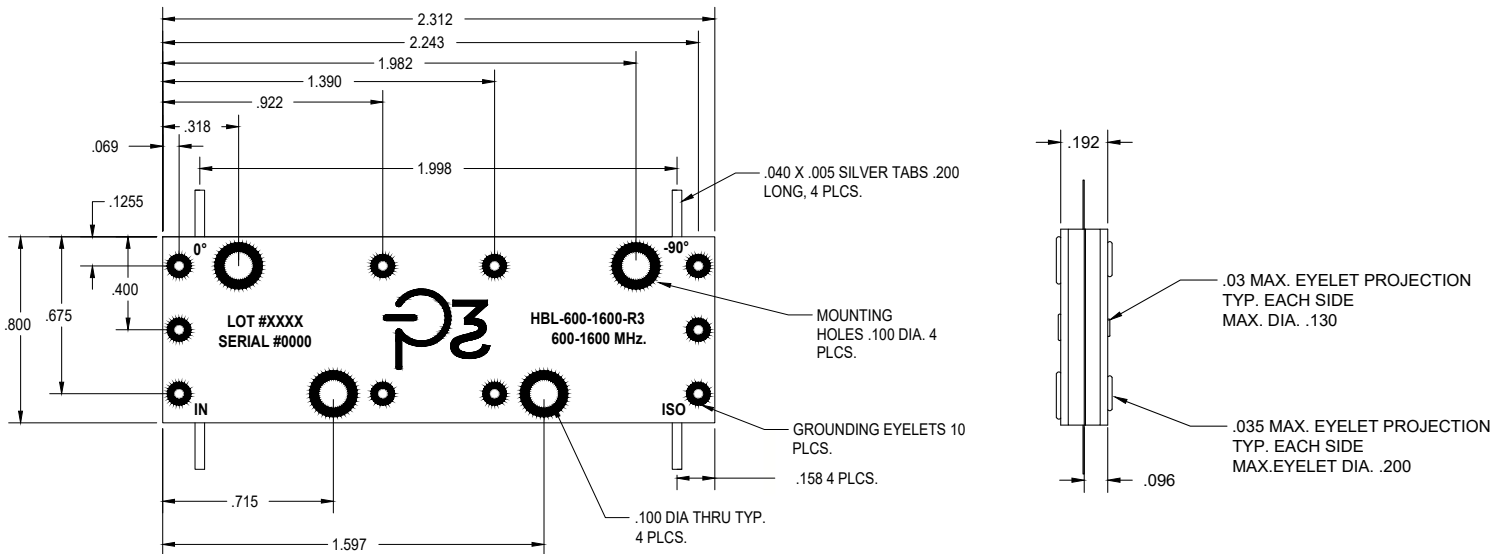

ELECTRICAL SPECIFICATION

Frequency:	600 - 1600 MHz.
Impedance:	50Ω
Power:	300 W cw
Insertion Loss:	<0.35 dB
Amplitude Balance:	±0.50 dB
VSWR:	1.35:1 Max.
Isolation:	15 dB Min.
Phase Balance:	±3° Max.
Operating Temp.:	-55°C To +85°C

MECHANICAL SPECIFICATION

Case Material:	Aluminum Alloy, 6061-T651
Finish:	Chem-Film Conversion, Clear. MIL-DTL-55413
Tab Material:	Silver, 99.99% Purity
Tab Size:	W=0.045" L=.150" T=0.005"
Eyelet Material:	Stainless Steel or Brass. nickel Plate, QQ-N-290
Marking:	LASER Engraved Per MIL-STD-130
Tolerance:	±.020" (Unless Specified)
Storage Temp:	-55°C To +150°C

All Specifications subject to change without notice

EXAMPLE

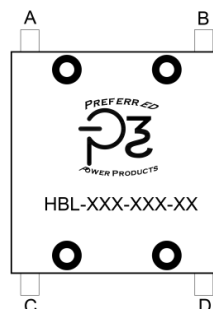

PHASE RELATIONSHIP FOR 90° HYBRIDS				
INPUT	OUTPUT			
	A	B	C	D
A	---	Termination	0°	-90
B	Termination	---	-90	0°
C	0°	-90	---	Termination
D	-90	0°	Termination	---





Typical Performance Data

10/18/2022 5:21:09 PM

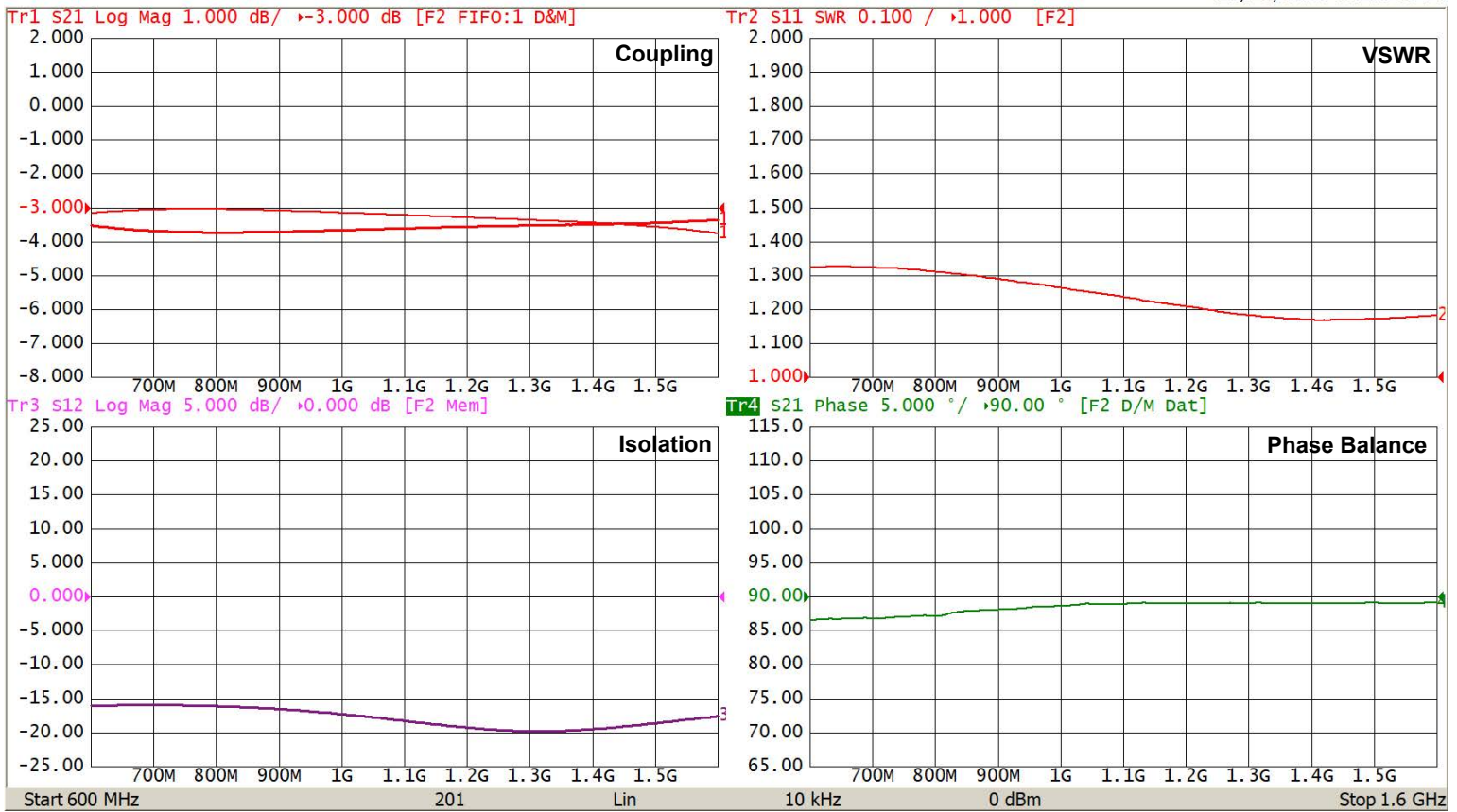

NOTES:

- 1). TEST DATA AND SPECIFICATIONS APPLY WHEN MOUNTED IN P3 TEST FIXTURE.
- 2). ALL TEST DATA IS TAKEN AT BASE-PLATED MAINTAINED @25°C USING A CALIBRATED NETWORK ANALYZER.
- 3). TEST FIXTURE DRAWING CAN BE PROVIDED UPON REQUEST.
- 4). A COMPLETE TEST FIXTURE MAY ALSO BE PURCHASED BY CONTACTING: sales@p3-rf.com

