

200 Watt 90° *HYBR-LINE* Coupler



250-1000 MHz

Model: HBL-250-1000-R2M



Frequency:	250 - 1000 MHz
Amplitude Balance:	±0.60 dB Max.
Power:	200 Watts CW
Phase Balance:	± 3° Typical
Insertion Loss:	0.40 dB Max.
Isolation:	19 dB Min.
VSWR:	1.30:1 Max. All Ports

HBL *HYBR-LINE* Series Drop-In Hybrid couplers provide High Power dividing or combining while exhibiting excellent phase and amplitude balance over continuous broadband operation. Solid compact designs are able to operate in a wide variety of environments, which include Medical, Industrial, Commercial wireless, Military, and Space. The **P3** library of designs allows for modifications of standard designs to be made quickly and inexpensively to meet specific requirements with short delivery times. Consult factory for special requirements or frequency ranges.

NOTES:

Material: Aluminum Alloy. 6061-T651
 Finish: Chem-Film, Clear Iridite MIL-DTL-5541F

Operating Temperature: -55°C to +85°C

Specifications subject to change without notice

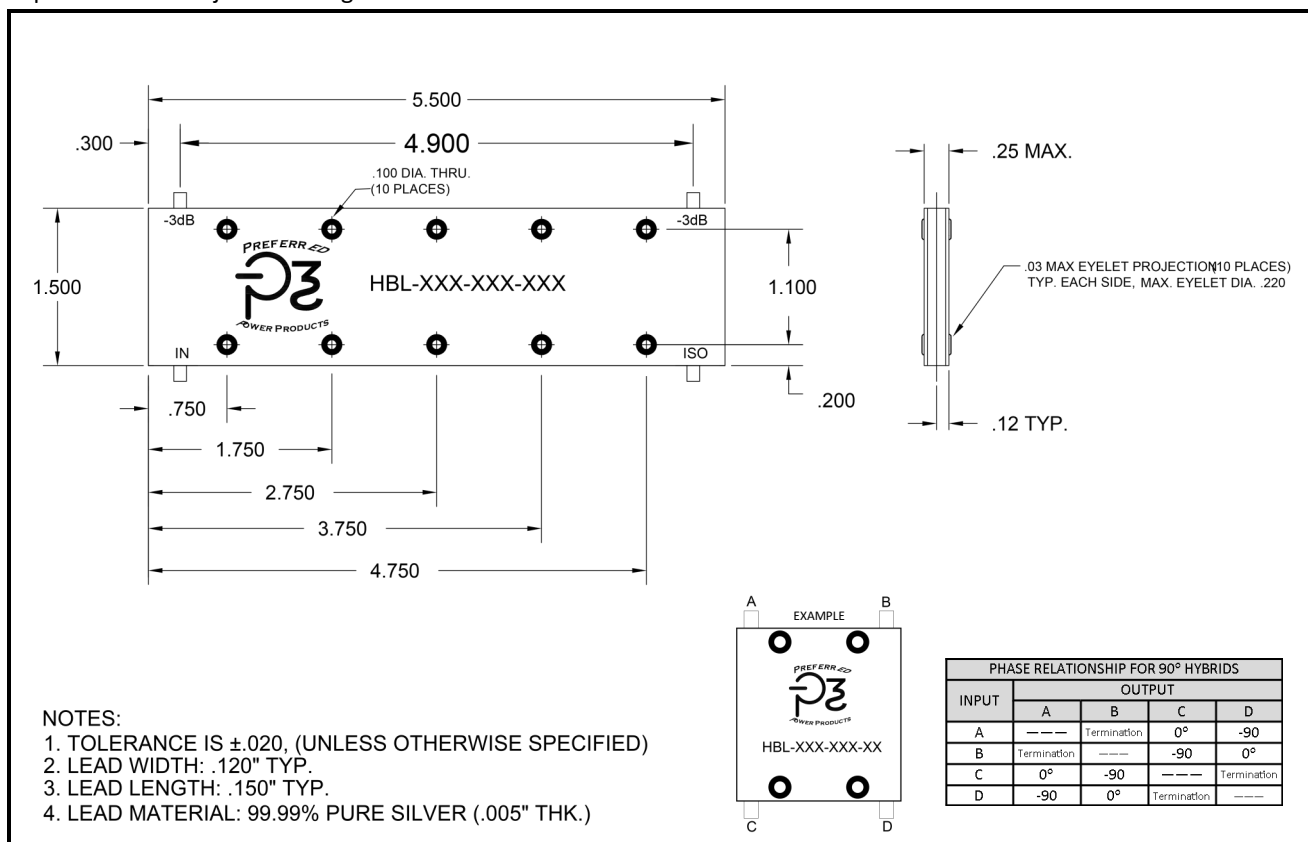

- NOTES:
1. TOLERANCE IS ±.020, (UNLESS OTHERWISE SPECIFIED)
 2. LEAD WIDTH: .120" TYP.
 3. LEAD LENGTH: .150" TYP.
 4. LEAD MATERIAL: 99.99% PURE SILVER (.005" THK.)

www.preferredpowerproducts.com

Tel: 1-772-291-2549 | sales@preferredpowerproducts.net

STUART, FL 34997